

Razor® XL Product Specification

**A carbide inserted snowplow blade system.
Guaranteed at least 3 times wear life of carbide and cover. References and case studies can be provided.**

Product Description:

The Razor® XL carbide insert blade system shall be an engineered system comprised of abrasion resistant steel cover integrated on a carbide insert blade with ¾ inch tall full radius tungsten carbide inserts, and heavy duty Winter Carbide Matrix® filled wear bars, securely welded on the back of each blade to form a single engineered blade assembly. The Razor® XL carbide blade system also shall include two (2) PlowGuard MAXX™ that have heavy duty Winter Carbide Matrix® inside, all mounting hardware (with thread locking fasteners), and installation instructions. All components are crated together in a palletized package. The blades shall be usable on any road surface and approved for high speeds.

Product Specification Details:

1. WEAR LIFE

- 1.1 Product shall be guaranteed to last a minimum of three times (3X) longer than a standard carbide insert plow blade and cover (standard blade defined as a 5/8" tall 25 degree trapezoid, tungsten carbide insert blade and hardened 5/8" x 6" cover blade).

2. REFERENCES

- 2.1 Manufacturer shall provide references for the system upon request validating wear life.

3. PACKAGING

- 3.1 All blade system components are to be provided in a single box or crate comprising of:

- a. All blade sections manufactured per specifications.
 - b. (2) PlowGuard MAXX™
 - c. (1) Grade 8 hardware kit including thread locking fasteners, flat washers, extended shoulder carriage bolts, and plow bolts.
- 3.2 Installation instructions included in package.
- 3.3 The blade system package is to be securely banded to a pallet providing adequate protection for common freight carrier handling, transportation, and receiving.
- 3.4 Packaging will provide adequate protection from the elements incurred during normal transportation and storage.

4. MAIN BLADE

- 4.1 The blade shall be high strength structural grade hot rolled flat steel.
- 4.2 Dimensions: 7" high x 3/4" thick x 3' or 4' length
- 4.3 Tolerance between hole spacing is +/- 1/16", non-accumulative, from center to center across full length of blade.
- 4.4 The groove for the carbide inserts shall be milled in the center of the blade edge.
- 4.5 Hole size and location of holes shall be per customer's requirements.

5. TUNGSTEN CARBIDE INSERTS

- 5.1 The tungsten carbide insert shall comprise the following total dimensions:
- a. Length: 1" nominal
 - b. Width: 0.36" min.
 - c. Height: 0.75" max.
 - d. Shape: Hammerhead (full radius)
- 5.2 Tungsten carbide insert shall be of a grade containing approximately 89% tungsten and approximately 11% cobalt binder by weight.
- 5.3 Original compounding specific gravity equal to 14.35-14.6
- 5.4 The insert hardness shall be 87.5-88.8 Rockwell A scale
- 5.5 Transverse rupture strength of 351,000 PSI minimum.

6. BRAZING

- 6.1 Each blade shall contain an approximate 1” length of carbide inserts for each 1” length of blade.
- 6.2 The carbide inserts shall be placed in line within the center-milled groove.
- 6.3 The carbide inserts shall be brazed on all sides using sound brazing practice, having no evidence of voids, shims, or fillers providing approximately 70,000 PSI shear strength.

7. STEEL COVER BLADE

- 7.1 Cover blade shall be heat-treated abrasion resistant steel.
- 7.2 Dimensions: 5/8” thick x 4” High.
- 7.3 Cover blade will have an approximate hardness of 44-52 Rockwell C.
- 7.4 Cover blade must include wear indicator notches for blade change notification.
- 7.5 Cover blade must include interlocking tabs for added rigidity.

8. CAST WEAR BARS

- 8.1 High impact Grade A-22 steel casting.
- 8.2 Wear bars will have a cavity of Winter Carbide Matrix® to be 7/8" min. in height for the full length of the casting.
- 8.3 Winter Carbide Matrix® must be fused to impact bar.
- 8.4 Each wear bar must contain a minimum of 10.00 in³ of Winter Carbide Matrix®.

9. ASSEMBLY WELDING

- 9.1 Each carbide insert blade has a cover blade welded to the front surface of the main carbide blade. This weld will provide adequate strength to retain the cover blade and interlock while in service.
- 9.2 A 3’ blade section will have two (2) wear bars and the 4’ section will have three (3) wear bars securely welded onto the blade. This weld will provide adequate strength to retain the moldboard shoes while in service.

10. PLOWGUARD MAXX™ GUARDS

- 10.1 Guards shall be high impact, A-22 steel castings.
- 10.2 Shall have three separate pockets to be fully filled with a minimum of 11.20 in³ of Winter Carbide Matrix® weld.
- 10.3 Winter Carbide Matrix® weld profile must be parallel and flush (plus/minus 1/32") to blade surface of guard. Winter Carbide Matrix® must be fused to the pockets of the steel castings.
- 10.4 Mounting holes are cast square holes to fit a 5/8" carriage bolt.
- 10.5 Guards will be Class 7 Orange™ texture powder coated to provide corrosion resistance and safer handling.

11. MOUNTING HARDWARE

- 11.1 The mounting hardware will consist of high-quality thread locking components consisting of Grade 8 extended shoulder carriage bolts, Grade 8 plow bolts, all metal lock nuts and flat washers. All items to be pre-counted and sealed for corrosion resistance.

12. FINISHED PRODUCT

- 12.1 Finished blade will be Class 7 Orange™ texture powder coated to provide corrosion resistance and safer handling.
- 12.2 Front edge of blade will be identified to avoid improper installation.
- 12.3 Finished blade shall comply with standard blade manufacturing tolerances.
- 12.4 Manufacturer's literature shall be furnished as required.

Example of an 11 ft system

ITEM NO.	PART NUMBER	DESCRIPTION	QTY.
1	RZXL3031223	Blade	1
2	RZXL3041223	Blade	2
3	CG8000CCL	Plowguard Maxx L	1
4	CG8000CCR	Plowguard Maxx R	1
Not Shown	KT-12-SHP-CG	Bolt Kit	1

KT-12-SHP-CG includes:
 (12) 5/8" Plow Bolts
 (6) 5/8" Extended Shoulder Carriage Bolts
 (18) Lock Nuts
 (18) Washers

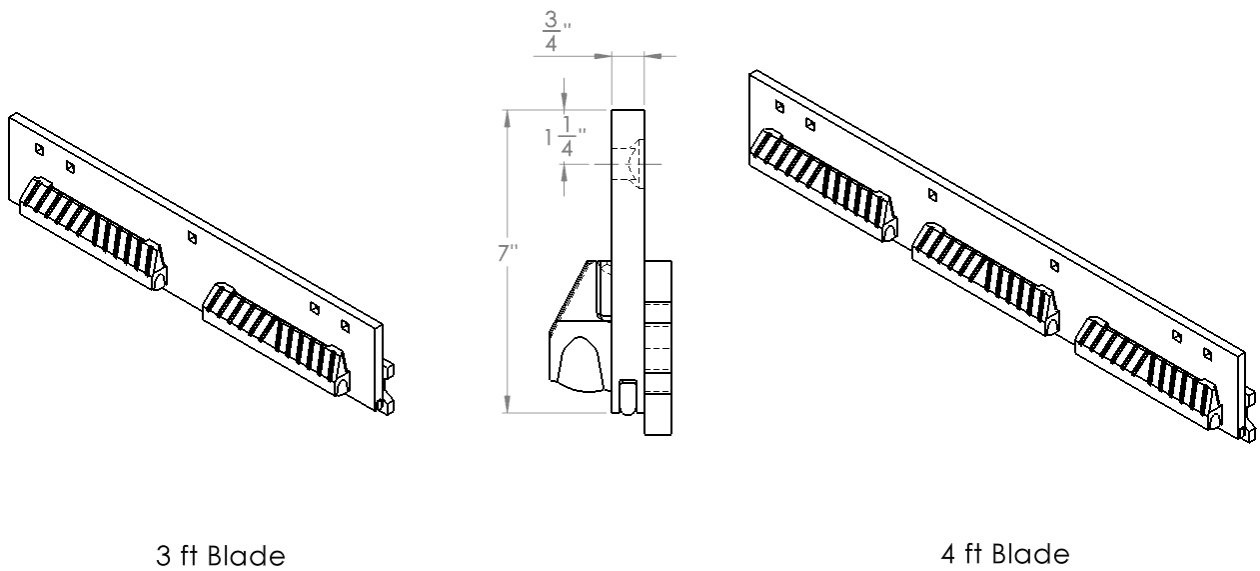
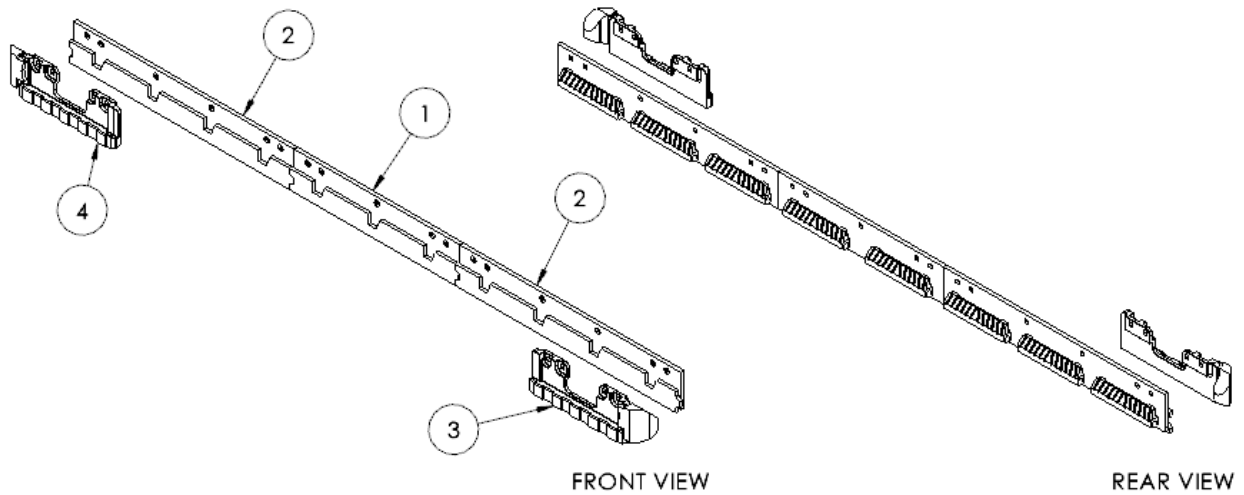

Image above shows an overview of components.